

NUMERICAL METHOD TO ESTIMATE TOLERANCES COMBINED EFFECTS ON A MECHANICAL SYSTEM

D. Cambiaghi, A. Magalinia and D. Vetturi

Keywords: statistical methods in mechanical design, tolerancing, simulation

1. Introduction

This contribution deals with a numerical method developed to estimate how the combined effects of several form and dimensional tolerances [ISO 1101:1983, ISO 286-1:1988], to be applied on a mechanical structure, influence the final three-dimensional location of the single constituting elements of this. Reference is made to the space program *Planck* aimed to investigate the short wave radiation coming from deep space. An instrument has been designed for the purpose, whose core probe is composed with a number of high frequency receivers (30 to 70 GHz), called *Feed Horns* [Bersanelli 1998].

Such receivers are roughly shaped as “hornets”, in the range of 100 to 200 mm in length. All such hornets must be aligned with mathematically defined alignment lines, all such lines converging to a theoretical focus point. The expected precision is dramatically high, as to require special care in the manufacturing of the hornets themselves and of the supporting frame. Furthermore the system is to be cooled down to a few Kelvin temperature, and the induced thermal deformations must be kept into account. To evaluate the possible misalignment errors has proved to be a challenging task. A dedicated procedure has been developed to take into account all the errors causes coming from manufacturing tolerances, coupling uncertainties and thermoelastic displacements and deformations.

This contribution disregards the analysis of any thermoelastic phenomenon and focuses on a numerical methodology which has been developed to solve the explained problem of misalignments prediction. Due to the relevant number of hornets a statistical method [Cox 2003, Vullo 1983] has been used to evaluate the error propagation, while the geometric attitude of each hornet as a consequence of such errors has been computed by way of special algorithms developed in the robotic science area [Legnani 1996]. The developed software and procedures allow optimising the error budget of the machining and surface finishing phase of each coupling surface. Nevertheless the presented approach has been developed to solve the aforementioned very specific problem, it is intended as a general numerical methodology to be applied to predict, during the design phases, the effects of tolerancing on the final manufactured mechanical object and to analyse how each specification acts in terms of practical results.

2. Methods

2.1 Geometrical approach

Considering a mechanical system, given by the combination of a certain number of single elements, a certain number of reference frames is put on each one of these. A first reference frame (say *Local*

Reference Frame– LR) changes its orientation and the position of its origin as consequence of the dimensional and geometrical specifications imposed to its owning mechanical element. Some other reference frames keep into account the effects of tolerances relating to the coupling of the considered mechanical element and those connected to it. These references are called *Fit Reference Frames (FR)*. The number of this kind of reference frames, for each element constituting the considered system, depends on how many components are connected to it; in fact, at least one reference has to be taken into account for each coupling connection relating the considered component. A certain number of further auxiliary reference frames may be put on each mechanical element; these references are used to evaluate rigid translations and rotations and do not change as consequence of the presence of any tolerance.

When a mechanical system is examined, it has to be modelled as a series of distinct elements; in this series all the components which have influence on the final position and orientation of the element of interest have to be considered. For example, relating to the studied system, the mentioned instrument is constituted by a series of four elements; the Feed Horn represents the last element of this series. A theoretical point called *Phase Centre* is defined on each Feed Horn. The three-dimensional location of the single Feed Horn is given by three co-ordinates relating its Phase Centre and three angles relating the spatial orientation of its geometrical axis.

Figure 1. Simplified mechanical model: series of three mechanical elements (A, B, C)

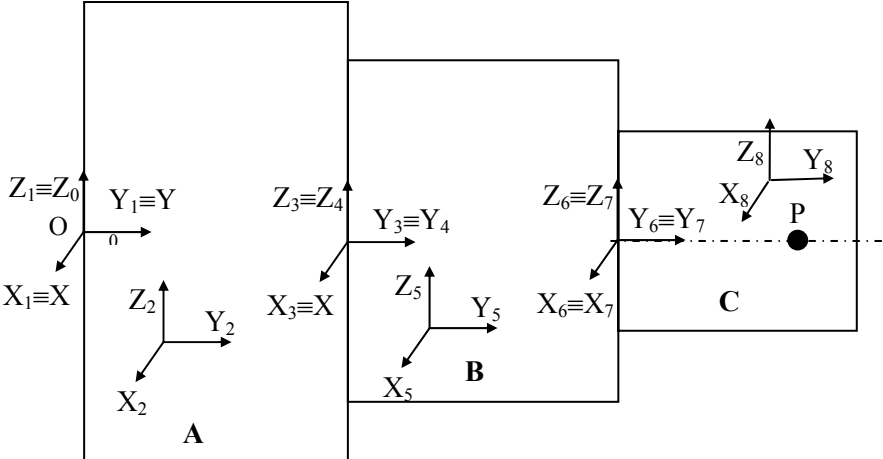

Figure 1 is intended to show the simplified model of a possible analysed mechanical system, which is reduced to a series of connected mechanical elements.

According to Figure 1, the O, X_0, Y_0, Z_0 reference frame represents the absolute co-ordinate reference system. It may be supposed that the interest of the analysis is in the determination of the three-dimensional location of the C element. Its six degrees of freedom may be thought of as given by the three spatial co-ordinates of a point belonging to it (P) and by three angles defining any geometrical axis integral with it. In this case, only those mechanical elements composing the overall system, which influence the final location of the C element, are kept into account to define the shown simplified mechanical model; so the series of components has to be seen as a cascade of elements, each one influencing the location of the following ones. Relating for example to the B element, three reference frames have been drawn on it: the X_4, Y_4, Z_4 reference represents fit references for the coupling of elements B and A; the X_6, Y_6, Z_6 reference keeps into account the effects of tolerances of coupling of B and C; the X_5, Y_5, Z_5 reference relates to the effects of internal specifications for the B element (local reference frame for B). The meaning of the other shown references should be clear from the figure (local and fit reference frames are defined also for A and C). It is to be noted that each reference frame is defined in the reference given by the one previous to it: so, the reference frame 1 is defined in the reference given by reference frame 0; reference frame 2 is given in regards to the reference system given by reference frame 1, and so on... reference frame 8 is given in the reference system represented by reference frame 7.

The Homogeneous Matrix approach [Legnani 1996] is adopted to define the orientation and the position of the origin point of each reference frame with regards to the one previous to it: so, according to the example of Figure 1, the M_{01} matrix describes reference frame 1 with regards to the absolute reference system (0); the M_{12} matrix describes reference frame 2 with regards to 1, and so on... the reference frame 8 is defined by M_{78} in reference system 7. So a homogeneous matrix corresponds to each reference frame considered for the treated mechanical system. Making the product of the mentioned matrixes (starting from M_{01} and ending with the M_{78} matrix) a M_{08} matrix is pointed out; it defines reference frame 8 in the absolute reference system (0) (see equation 1).

$$M_{08} = M_{01} \cdot M_{12} \cdot M_{23} \cdot M_{34} \cdot M_{45} \cdot M_{56} \cdot M_{67} \cdot M_{78} \quad (1)$$

Once the M_{08} matrix is computed, the three angles defining the orientation of the reference frame 8 with regards to the absolute reference can be extracted from its terms (making use of suitable equations and considering a specific convention to define angles). If the position of any point is known in reference 8, by equation 2, it can be determined also in reference 0.

$$P_0 = M_{08} \cdot P_8 \quad (2)$$

Where P_0 is the position of the point P (with reference to Figure 1), P_8 is its position in reference 8. So the six degrees of freedom (three angles and three translations) of any mechanical element (in this case the C element has been taken into account) are defined.

2.2 Numerical approach

The adopted numerical approach is based and the Monte-Carlo simulation method [Cox 2003, Press 1988].

Once the simplified model has been defined as explained in section 2.1, each uncertainty contribution (having influence on the final three-dimensional location of the element of interest) is thought of as a random variable [Levi 2000, Hines 1990] and so a proper probability distribution [Levi 2000, Hines 1990] function is supposed for it (according to Figure 1, all the uncertainty contributions to the final three-dimensional location of element C are considered). Three probability distribution function have been taken into account: Uniform distribution, Gaussian distribution and Triangular distribution. Each tolerance imposed by design gives a certain number of uncertainty contributions; parameters defining the probability distribution function of the single contribution depend on the given tolerance limits.

A series of n values is generated for each uncertainty contribution following the proper supposed probability distribution function (and so within the prescribed design limits for the considered tolerance). So a series of n vectors is provided, the components of each vector representing an uncertainty contribution; each vector represents a possible situation, consequence of the given tolerancing system. In correspondence of each situation (vector) all the matrixes defining the different reference frames considered for the treated system are computed. According, for example, to Figure 1, all the eight matrixes are calculated and the M_{08} matrix is computed (see equation 1); so, for each one of the n situations, the values to be assigned to the six degrees of freedom relating to the C element are estimated. Each degree of freedom defining the C element spatial location has now to be seen as a random variable, which assumes a sample of n values. So a mean value and a standard deviation are calculated for each of these (defining an estimated probability distribution). So the expected three-dimensional location for the C element is known: a mean value and a related uncertainty (equal to two or three standard deviations) is assigned to the six mentioned degrees of freedom. In the aforementioned study case relating a measurement instrument for space applications, the three-dimensional location of each Feed Horn antenna has been computed by the explained method.

By the described statistical approach a sensitivity analysis of the final three-dimensional location of any mechanical element in the considered structure to the different uncertainty causes (and so to each tolerancing specification) can easily be conducted. For example, keeping into account only one of the six degrees of freedom relating the considered component, an analysis can be conducted considering

all the uncertainty contributions acting together and, so, computing the overall variance of the random variable describing the chosen degree of freedom. Variance estimations can also be conducted keeping into account alternatively only one of the considered uncertainty causes, so to calculate the percentage contribution of this with regards to the total calculated variance. This investigation should be repeated for each degree of freedom and for all the uncertainty contributions, to define how the different specifications given in design affect the final three-dimensional location of a mechanical element of interest in the considered mechanical structure. According to the aforementioned measurement instrument for space short waves radiation inspection, the explained method has been applied to investigate how and how much each design specification relating form, dimensional and fit tolerances affect the final alignment of each Feed Horn.

3. Methodology application

This section is intended to show a very simple example of application of the explained analysis method, specifically focusing on the geometrical approach. A simple mechanical structure is modelled as a series of two components (see Figure 2): a flange (element A) and a conical flanged element (element B). These components are coupled with two pins, which are fitted in suitable holes. The component A is supposed to be fixed to the ground. Four reference frames are considered.

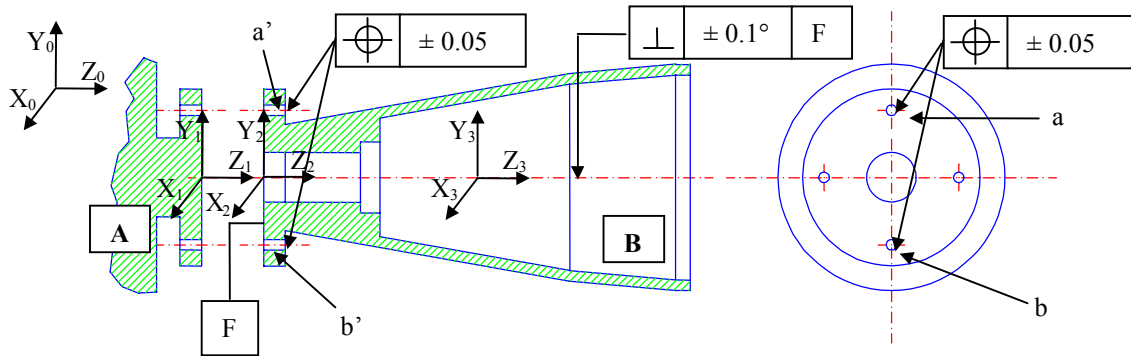

Figure 2. Example of a possible analysed mechanical system

Reference frame 0 refers to the absolute reference system (integral to ground). Reference frame 1 is integral to the A element; it keeps into account the effects relating the coupling of this element and B, so it changes its orientation according to the specifications given for the location of the pins holes on A. On the side of B, two references are considered: reference frame 2 relates to the coupling of this element with the A component, in relation with the location pins holes; reference frame 3 relates to internal tolerances for element B (verticality of the geometrical axis with regards to the F plane). Three homogeneous matrixes are defined. M_{01} describes the orientation and the position of the reference frame 1 in the absolute reference (0): this matrix keeps into account the effects of the location specifications given for the pins holes. The changing in positions of these holes gives a rotation of the reference 1 around the Z_0 axis and translations on the X_0Y_0 plane. M_{12} describes the position and orientation of reference frame 2 in the reference given by 1. It changes as consequence of location specifications given for the pins holes on B. M_{23} defines reference frame 3 in reference 2. It keeps into account the specification of verticality of the axis of the B element: here two rotations (around the x and y directions of 2) have to be considered.

So, in this example, six uncertainty contributions, depending from five specifications have to be considered. The following Table 1 resumes these specifications and makes a correspondence for them with the different uncertainty contributions and for these with the matrix keeping them into account.

M_{03} matrix is given (equation1) as the product of all the aforementioned matrixes (M_{01} , M_{12} , M_{23}); it keeps into account all the combined effects of tolerances on the location and orientation of the B element in the absolute reference system.

If a suitable probability distribution function distribution is taken for the uncertainty contributions (for example uniform distribution function, with mean value equal to zero and amplitude given by the

tolerancing limits) the Monte-Carlo analysis can be started, generating n possible situations (see section 2.2).

Table 1. Uncertainty contributions

<i>Specification</i>	<i>Uncertainty contributions</i>	<i>Matrix</i>
<ul style="list-style-type: none"> • Location of pin hole a • Location of the pin hole b 	<ul style="list-style-type: none"> • Translation of ref. 1 in the y direction of ref. 0 • Translation of ref. 1 in the x direction of the ref. 0 (Rotation of ref. 1 around the z axis of ref. 0) 	M_{01}
<ul style="list-style-type: none"> • Location of pin hole a' • Location of the pin hole b' 	<ul style="list-style-type: none"> • Translation of ref. 2 in the y direction of ref. 1 • Translation of ref. 2 in the x direction of ref. 1 (Rotation of ref. 2 around the z axis of ref. 1) 	M_{12}
<ul style="list-style-type: none"> • Verticality 	<ul style="list-style-type: none"> • Rotation of ref. 2 around the x axis of 1 ref. 1 • Rotation of ref. 2 around the y axis of 1 ref. 1 	M_{23}

4. Results

This section is intended to show some qualitative results obtained by the application of the presented numerical method to the estimation of Feed Horns misalignment for the aforementioned space measurement instrument (with reference to the *Planck* space program).

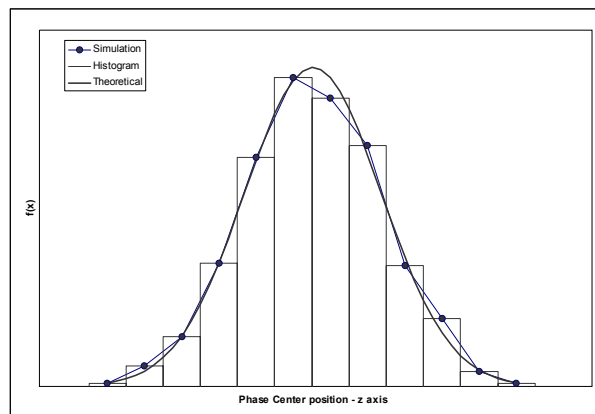

Figure 3. Qualitative probability distribution for a co-ordinate of a Feed Horn Phase Center

Figure 3 shows the final probability distribution (in terms of histogram and probability density function [Levi 2000, Hines 1990]) obtained for one degree of freedom (a translation) of a Feed Horn. The results of simulations are compared with a theoretical probability density function curve, for which a Gaussian distribution has been assumed.

According to Figure 3, a Uniform probability distribution function has been assumed for all the uncertainty contributions. It may be noticed that the final distribution function numerically predicted for the considered degree of freedom is very close to a Gaussian probability distribution function curve. This is in good accordance with what could be expected by theory [Levi 2000, Hines 1990, Dietrich 1991].

5. Key conclusions

A numerical method to estimate tolerances effects on the position and the orientation of a mechanical element within a mechanical complex system has been provided. The implementation of this method gives satisfactory results for simple theoretical study cases and also for its application relating to the alignment analysis of some antennas called Feed Horns, composing a measurement instrument for space applications.

Although the method has been proposed to solve a specific design problem, it has to be thought of as a general approach to be applied for:

- the estimation of the uncertainty [UNI CEI ENV 13005 2000] level in terms of position and orientation concerning any mechanical component composing the analysed system, as consequence of the accuracy of the imposed dimensional and geometrical specifications;
- the sensitivity analysis relating to the uncertainty contributions of each imposed design tolerance to the final results (in terms of position and orientation of one specific element); this kind of analysis is useful, when a budget value of positioning error is given for a certain number of elements constituting a mechanical system, to investigate in case which tolerance may be increased in terms of accuracy, or, on the other side, which may be made less accurate or even erased;
- the evaluation of the overall quality of the design process, which should be considered in relation with the accuracy level imposed by the chosen tolerances configuration, keeping into account technical but also economical aspects.

It is clear that numerical results given by the proposed methodology should be checked by measurement experimentation to be conducted on the manufactured mechanical system, keeping into account that the measurement process is itself affected by a certain level of uncertainty [ISO/TS 14253-2:1999]; so the check should be thought of as a verification of compatibility between the numerically predicted ranges of values and the actually measured ones.

Acknowledgements

Many thanks to LABEN S.p.A., Vimodrone (Milan), ITALY. LABEN has ordered and financed this research.

References

- Bersanelli et al.*, "A Low-Sidelobe, High Frequency Corrugated Feed Horn for CMB Observations" *Experimental Astronomy*, 1998, Vol.8, Issue 3, pp. 231-238.
- Cox M. et al.*, "Evaluation Of Measurement Uncertainty Based On The Propagation Of Distributions Using Monte Carlo Simulation", *Measurement Techniques*, Vol. 46, No. 9, 2003.
- Dietrich C. F.*, "Uncertainty, Calibration and Probability", 2nd edition, Adam Hilger USA, 1991, pp. 112-132.
- Hines W. W., Montgomery D. C.*, "Probability and statistics in engineering and management science", Wiley New York, 1990.
- ISO 1101:1983, "Technical drawings -- Geometrical tolerancing -- Tolerancing of form, orientation, location and run-out -- Generalities, definitions, symbols, indications on drawings", ISO, 1983.
- ISO/TS 14253-2:1999, "Geometrical Product Specifications (GPS) -- Inspection by measurement of workpieces and measuring equipment -- Part 2: Guide to the estimation of uncertainty in GPS measurement, in calibration of measuring equipment and in product verification", ISO, 1999.
- ISO 286-1:1988, "ISO system of limits and fits -- Part 1: Bases of tolerances, deviations and fits", ISO, 1988.
- Legnani G., Casolo F., Righettini P., Zappa B.*, "A Homogeneous Matrix Approach to 3D Kinematics and Dynamics. Part 1: theory. Mechanisms and Machine Theory", *The Scientific Journal of IFToMM*, Pergamon Press UK, 1996, Vol.31, No.5, pp.573-58.
- Levi R., Vicario G.*, "Calcolo delle Probabilità e Statistica per Ingegneri", Esculapio Italy, 2000.
- Press W. & al.*, "Numerical Recipes in C", Cambridge University Press UK, 1988.
- UNI CEI ENV 13005, "Guide to the Expression of Uncertainty in Measurement", UNI Italy, 2000.
- Vullo V.*, "Calcolo delle tolleranze con metodi probabilistici e criteri di minimo costo", CLUT Torino (Italy), 1983, pp. 2-12.

Danilo Cambiaghi, Full Professor of Machine Design
 Università degli Studi di Brescia, Dipartimento di Ingegneria Meccanica
 via Branze 38, 25123 Brescia, ITALY
 Telephone: +39 (0)30 3715552, Telefax. +39 (0)30 3702448
 E-mail: andrea.magalini@unibs.it